



## Table of Contents

What Does Your Bedroom Say About You? .....	2
Balancing Mobiles .....	6
Appendix A: Puzzles .....	8
Learn About Healthy Eating and Get Moving! .....	11
Titre de l'activité .....	<b>Error! Bookmark not defined.</b>
Titre de l'activité .....	<b>Error! Bookmark not defined.</b>



# What Does Your Bedroom Say About You?

## Information for students

- Take a photograph of your room.
- Watch this YouTube video: <https://safeyoutube.net/w/BAf9>
- Identify the following in your room.
  - **Identity Claim:** Which objects in your room tell us how you want to be perceived by others? Your books, your music, your posters, your decorations, etc.
  - **Behaviour Residue:** Which objects in your room are unintentional? For example; Are there clothes on the floor? Are there empty coffee cups in your room?
  - **Thoughts and Feeling Regulators:** Which objects in your room give you solace and comfort? Do you have a favourite pillow? Do you have a candle that you light?
- Using the questions above to guide your thinking, write a page or two about how these objects inform others about you and your personality. Do you think these objects give an accurate portrait of who you are?
- Share your findings with a friend.

## Materials required

- Device with Internet access
- Paper and writing materials

## Information for parents

- Do you think your child's bedroom reflects their personality?
- Talk to your child what your bedroom looked like when you were your child's age



# Mon premier potager

## Information for students

- Lis [Le territoire agricole du Québec](#)
- Lis l'article '[Comment créer son premier potager en 7 points](#)'
- Consulte '[Les fermes Lufa](#)'
- Consulte et inspire-toi des recettes québécoises qui se trouvent sur les sites suivants :
  - [Ricardo cuisine](#)
  - [Recettes du Québec](#)

## Tâche – Mon premier potager (Production écrite)

Le gouvernement veut encourager la population québécoise à acheter des produits du Québec. Tu veux contribuer à cette cause en créant ton propre jardin potager. Tu t'informes sur le sujet et tu passes à l'action.

**Projet 1** : Crée une affiche promotionnelle du potager : vente des produits que tu produiras.

**Projet 2** : Rédige un petit rapport sur ton premier potager (texte descriptif/explicatif). Organise-le à ton goût, mais assure-toi de parler des informations suivantes :

- Indique les types de potagers qui existent dans ta région. Quel produit cultive-t-on dans ta région ? Explique pourquoi tu as décidé de faire pousser certains produits dans ton potager. Combien cela coûtera-t-il pour créer ton potager et à quel prix vas-tu vendre tes produits ?
- Explique l'effet de la météo sur le modèle de potager que tu vas créer (par exemple : potager interne, potager externe, etc.)
- Illustre comment tu vas créer ton potager. Fais un diagramme illustré. Indique l'impact qu'aura la construction de ton potager sur ton environnement (par exemple : quelles seront les bonnes pratiques que tu utiliseras pour créer ton potager ?) Tu peux même créer ce potager sur Minecraft.

**Pour aller plus loin : Crée une production écrite et/ou une production orale.**

**Projet 3** : Livre de recettes du terroir du Québec : Crée un livre de tes recettes préférées. Assure-toi de choisir/créer des recettes qui contiennent des ingrédients que tu vas faire pousser dans ton potager. Libre à toi d'organiser ton livre à ton goût.

**Projet 4a** : Site web - Crée un site web. Le but de créer un site web est d'inciter les gens à consulter ton entreprise (voir l'exemple sur le site web [lepanierbleu.ca](http://lepanierbleu.ca)). Ainsi, il sera important de bien organiser les onglets de ton site.

**Projet 4b** : Crée une vidéo promotionnelle en utilisant les informations que tu as recueillies.



### Pour aller encore plus loin

Partage ton travail sur le Padlet suivant [Mon premier potager](#) Consigne de partage : indique seulement ton prénom dans ton document et dépose ton travail dans la colonne de ta région.

### Materials required

#### Mon premier potager

- Tout ce dont tu auras besoin pour bricoler :
  - Du papier carton pour ton affiche
  - Des feuilles lignées et un vieil album de photos, par exemple, un duotang ou un cartable, pour ton plan d'affaire
  - Des livres de recettes à la maison
  - Des magazines de cuisine
- Si tu préfères faire le tout sous forme numérique, tu peux utiliser :
  - un logiciel de traitement de texte (Word, Google Doc) ou un site web (Google sites, [Webself](#), [Adobe Spark](#), [MadMagz version gratuite seulement](#), [Flipsnack version gratuite seulement](#))
  - un logiciel de création de diapositives (comme PowerPoint, Sway)
  - une application de création de livre (Book Créator)
  - une application/site web (Canva, Pinterest)
  - une application/logiciel pour l'enregistrement de ta voix tels que <https://www.makewebvideo.com/fr/templates/popular> <https://www.voicebooking.com/fr/generateur-voix-off-gratuit>, Screencastify ([version gratuite](#)) ou Adobe Spark (voir <https://spark.adobe.com/make/video-maker/>)

#### Trouver des conseils pour la rédaction de tes textes ici :

- LEARN – [Série comment faire](#)
- Allôprof - [Les textes courants](#)
- Vérificateur de grammaire <https://www.scribens.fr/> OU <https://bonpatron.com/fr/>



## Information for parents

### About the proposed activity

Your child will practise:

- (Cycle 1 Geography) Lists the main agricultural products (crops) of the territory studied
- (Cycle 1 Geography) Establishes a connection between certain characteristics of the climate and the infrastructure of the agricultural territory studied (e.g. the desert climate of central California makes it necessary to construct dams and develop irrigation systems; Québec's harsh winter conditions make it necessary to build greenhouses to ensure year-round supply of certain vegetables)
- (Cycle 1 Geography) Explains consequences of certain farming practices for the environment (e.g. intensive fruit tree cultivation requires the use of strong fertilizers, which contributes to soil nutrient depletion; annual irrigation of vegetable crops requires large amounts of water, which reduces groundwater levels)
- (FSL all levels of secondary) Understands the main points of short articles (read, seen or heard) on familiar topics
- (FSL all grades) Writes simple or complex texts about experiences, events, and/or topics of personal interest
- (FSL all levels) Expresses ideas and defends opinions accurately

You may be able to:

- help your child understand the texts (read, seen or heard)
- help your child complete their written text (poster, brochure, magazine and/or website)
- discuss with your child the possibility of starting a family garden : [How to start a community garden](#)



# Balancing Mobiles<sup>1</sup>

## Information for students

- The puzzles in Appendix A below will allow you to practice the kind of thinking that will help you learn how to make sense of algebraic equations.
- The puzzles become increasingly more challenging. See how far you can get. Try them on your own, and use the available hints, if needed.
- Instructions: The hanging mobiles are made with shapes, strings and beams. The beams and the strings have no value. Only the shapes have value. In some puzzles the value of the mobile is shown at the top, as in the example below. Sometimes you need to use other clues. Your goal is to figure out the value of each shape to make the mobile balance.
- Try the example below:

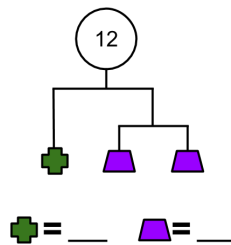

- For the example, did you figure out that since the mobile has a value of 12, each end of the top beam must have a value of 6. The cross is therefore worth 6 (half of 12). The other end of the top beam also has a value of 6, but this value is shared equally between the two trapezoids on the lower beam. Each trapezoid therefore has a value of 3 (half of 6).

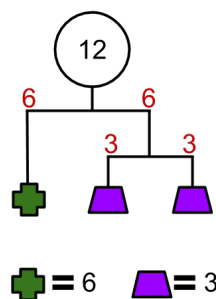

- Extensions:
  - Try to create an equation for the value of the mobile by using variables.
  - Create your own mobile puzzle and have someone else solve it.

<sup>1</sup> Education Development Center. "SolveMe Mobiles: Explore, Deduce, Create Puzzles #13, #16, #62, #64, #132, #133 (n.d.) Retrieved April 24, 2020, from <http://solve.me.edc.org/Mobiles.html>



### Materials required

- Writing materials
- Appendix A: Puzzle sheet. Students can also complete different puzzle mobiles interactively at <http://solve.me.edc.org/Mobiles.html>.

### Information for parents

- Read through the instructions and the practice example with your child, if needed.
- Encourage your child to think about how they determined the value of each shape, and have them explain this orally or in writing. The solutions to each mobile are at the bottom of the last page of Appendix A.



# Appendix A: Puzzles

## Mobile #1

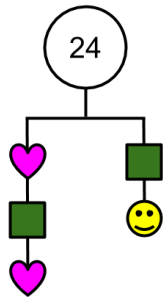

♥ = 2    ■ = \_\_\_    😊 = \_\_\_

### Hints:

- Use the given information to determine the value of each end of the beam.
- Use the given value of the pink heart to determine the value of the green square and the value of the yellow Happy Face.

## Mobile #2

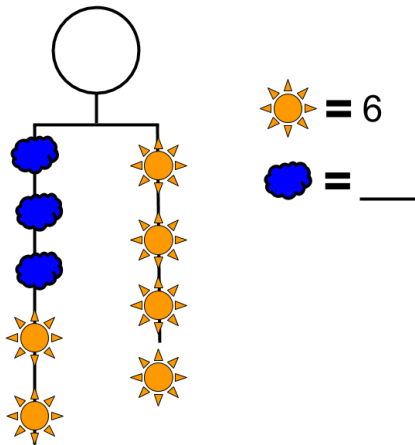

### Hints:

- Given the value of each orange sun, determine the value of the right side of the beam.
- Use that value to determine the value of the left side.
- Use the given value of the orange sun to determine the value of blue cloud.





### Mobile #3

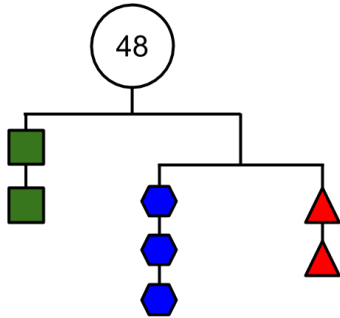

Hints:

- Use the given information to determine the value of each end of the top beam.
- Use the given value of the green square to determine the value of the blue hexagon and the value of the red triangle.

$\blacksquare = 12$     $\hexagon = \underline{\quad}$     $\blacktriangle = \underline{\quad}$

### Mobile #4

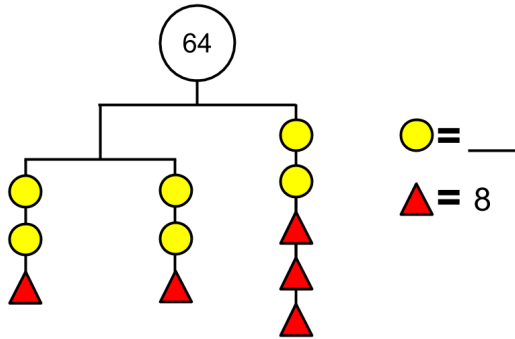

Hints:

- Use the given information to determine the value of each end of the top beam.
- Use the given value of the red triangle to determine the value of each yellow circle.

$\circ = \underline{\quad}$   
 $\blacktriangle = 8$

### Mobile #5

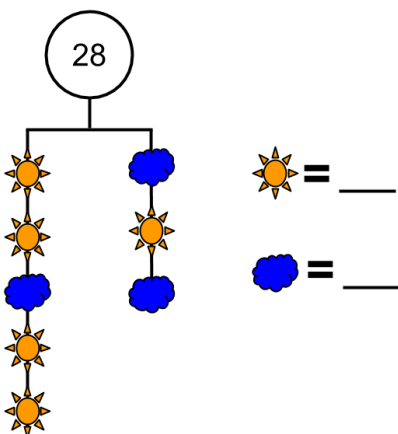

Hints:

- Use the given information to determine the value of each end of the beam.
- Determine the relationship between the value of an orange sun and the value of a blue cloud.

$\odot = \underline{\quad}$   
 $\text{cloud} = \underline{\quad}$



Mobile #6

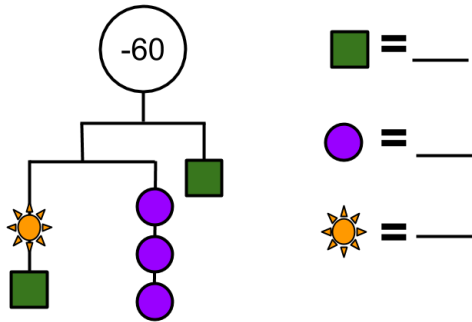

Hints:

- Use the given information to determine the value of each end of the top beam.
- Use the value of each end of the top beam to determine the value of each of the three purple circles?
- Use the value of the green square to determine the value of the orange sun.

Mobile #1	Pink heart = 2	Green square = 8	Yellow Happy Face = 4
Mobile #2	Orange sun = 6	Blue cloud = 4	Total = 48
Mobile #3	Green square = 12	Blue hexagon = 4	Red triangle = 6
Mobile #4	Red triangle = 8	Yellow circle = 4	
Mobile #5	Orange sun = 2	Blue cloud = 6	
Mobile #6	Green square = -30	Purple circle = -5	Orange sun = +15

Solutions:



# Learn About Healthy Eating and Get Moving!

## Information for students

### Activity 1: Learn about the Canada Food Guide

- Watch this video (1 min 51 sec), then explore the food guide website.
- Answer these questions:
  - What are the three types of food that should make up most of your meals?
  - What beverage does the food guide encourage you to choose most often?
- Overall, do half of your meals and snacks consist of fruits and vegetables? Can you think of ways to increase the amount of fruits and vegetables you eat? Check out the recipe section on the food guide website for snack ideas.

### Activity 2: Get moving!

- Have you ever heard of Poi or seen it being performed? Watch [this video](#) for an introduction to Poi.
- Make your own homemade Poi. [This video](#) will teach you three easy methods.
- Try the movements/challenges suggested in the following videos:
  - Video: [Challenge 1 – The one-handed wheel](#)
  - Video: [Challenge 3 – The one-handed helicopter](#)
  - Playlist: [Discover the exciting challenges of the art of poi](#)
- If you have safety goggles, wear them to protect your eyes.

If you are up for practicing your French and want to explore more activity ideas, visit the [Reste actif!](#) website.

## Required materials

- Depending on the video instructions and the type of Poi you chose to make



## Information aux parents

Children should:

- Learn about the Canada Food Guide
- Create a Poi and explore different movements with it...

Parents could:

- Discuss the Canada Food Guide with their children
- Join their children in learning some Poi techniques



# Autobiographical Collage Series

## Information for students

- Collage is the art of combining materials (paper, photographs, fabric, etc.) on a backing made of paper or another material to create a unique expressive composition.
- This assignment will have you explore the art of collage by doing a series of three autobiographical collages. The theme of the collages is you!
- Start by gathering images, colors, photos words from magazines or print outs that express who you are and how you feel. Express yourself, show us who you are, how you are feeling, what you may like and or dislike. It's a great way to think about ourselves visually. If bling is your thing, show us! If sports, music, pop culture, family or cooking is what you are about, then let's see it! Have fun and try to complete the series. Feel free to draw, doodle and color parts of your collages.
- Draw the outline of a shape (square, rectangle, or circle) on your backing paper to create a border for your collage. You can also work in a free-form style using the whole surface.

## Materials required

- Glue, glue stick, tape, scissors, ruler, pen or pencil
- Coloured pens, markers and pencils for drawing (optional)
- Paper or sketchbook (11" x 8.5" minimum size)
- Magazines, newspapers, photos, found images, recycled papers, etc.
- Optional: ribbon, fabric swatches

## Information for parents

- Link for a basic tutorial on how to create a collage; <https://youtu.be/0d9G1NqqiGo>



# World on Your Plate

## Information for students

- We don't always stop to notice where our food comes from, but behind everything we eat, there is a very large food industry hard at work making sure that there is food in the stores and on our plates. Where does all this food come from?
- In this activity, you will be looking at labels and packaging to find the origin of food items. Everything we eat, from unprocessed fruit, vegetables, meat and fish, to prepared foods such as soups, crackers and cookies, comes from somewhere.
- Look closely at the packaging a food item comes in. You should be able to find the name of the company that produced the food item and where it is from.
- To keep track of where your food comes from, you can use the template provided below or create your own recording method. Feel free to be creative by adding drawings, flags or logos!
- The activity can be done for one or more meals. If you or someone else at home makes a recipe, you can adapt this activity by finding out where all the ingredients come from.
- After you have completed the activity, you will be more aware of where your food comes from and the major role the food industry plays in the economy of certain regions. Ask yourself what you have learned about where your food comes from. You could also try to look up where these places are in Québec, Canada or elsewhere in the world. You could even draw a map and put the items you found on that map to get a visual sense of where your food comes from.
- If possible, share your work with your teacher or your school!

## Materials required

Useful resources, depending on personal preferences and availability:

- device with Internet access for maps (not essential)
- writing and drawing materials (paper, pencils, coloured pencils, etc.)
- food labels from food containers or packaging, stickers on fruit and vegetables)

## Information for parents

- This activity is suitable for all ages.
- Some students may require support in reading the instructions and getting started.